

050-1100
Family - 8mm Single
Rotor Latch



This robust automotive style single rotor latch is designed for light to medium duty applications for on or off-highway hoods, compartments and access panels. This design allows ease of interface with TriMark's range of external and internal methods of activation for application flexibility.

- Interior door thickness of 44mm (1.73") or greater
- Light to medium duty doors of 25 kg (55 lbs.) with door seal pressure no greater than 20 kg (40 lbs.)
- 8mm diameter hoop strike

FEATURES/BENEFITS:

- Compact size and shape; allows maximum use of door space and minimizes visibility issues
- Rotor provides for vertical clearance of strike allowing for door sag, misalignment and ease of installation
- Product case design provides for multiple latch actuation direction and locations for application flexibility

Global Locations:

TriMark Corporation
500 Bailey Avenue
P.O. Box 350
New Hampton, Iowa 50659
United States
Tel: 641-394-3188
Fax: 641-394-2392
1-800-447-0343
www.trimarkcorp.com

TriMark Europe
Cedar Court
Walker road
Bardon Hill
Coalville LE67 1TU
United Kingdom
Tel: +44(0)1530 512460
Fax: +44(0)1530 512461
www.trimarkeu.com

TriMark (Xuzhou)
Building A5 Jingwu Road
Xuzhou Economic
Development Zone
Xuzhou, Jiangsu
221004 PR China
Tel: +86 516 8773 0018
Fax: +86 516 8773 0058
www.trimarkcn.com



TriMark. Interactive. Product. Selector



TriMark



TriMark Corporation

AVAILABLE:

- Versions are available to allow direct or remote actuation from exterior handles and interior releases
- Platform allows for reuse of existing actuation trip levers (050-0100)
- Multiple actuation directions and locations
- Standard 8.4mm diameter through axles or optional M8 X 1.25 threaded axles

FINISH:

- Zinc plated, clear chromate steel components

MATERIAL:

- Case halves: High strength steel
- Springs: Non-corrosive stainless steel

INSTALLATION:

- Easy to install, mounts with (2) M8 X 1.25 or 5/16 fasteners (not included)
- Tighten to the manufacturers' recommended torque value, however, do not exceed 22.2 N-m (200 in-lbs)
- Mount only to the front plate side

U.S. Patent No. 8,075,027

Individual part dimensions are for reference only. Refer to individual part drawings for complete dimensions, specifications, and installation procedures. Engineering assistance and application drawings are available.

CAUTION: Latch does not meet FMVSS 206 (ECE R11) load requirements.

For more information visit
www.trimarkcorp.com

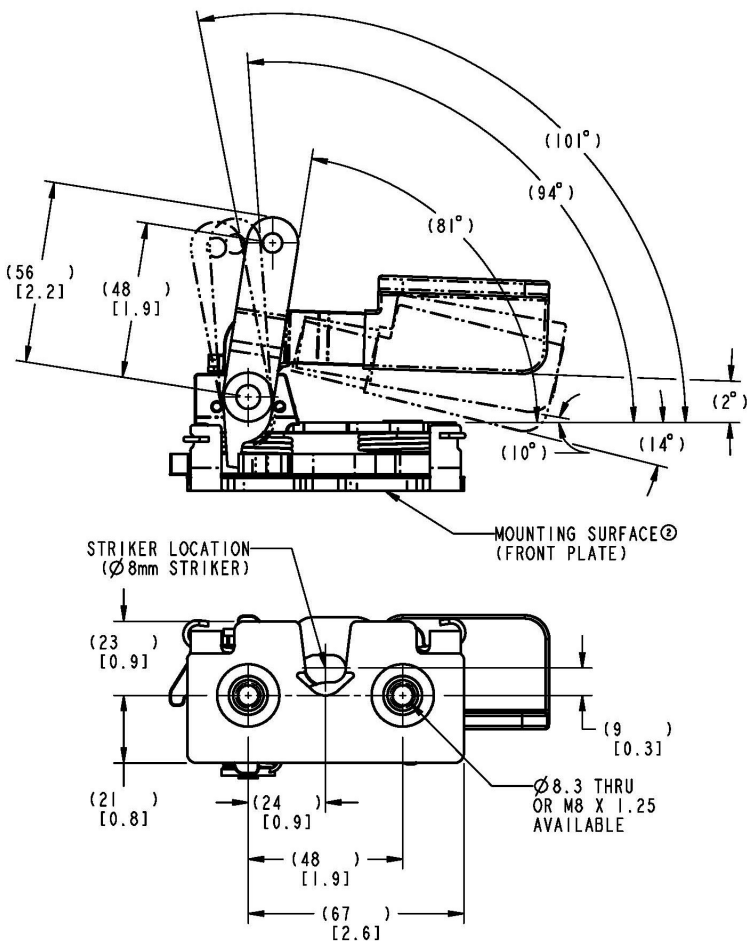

050-1100 Family:

- | | |
|----------|----------------------------|
| 050-1100 | Two-Position 8mm Striker |
| 050-1107 | Two-Position, Coaxial Trip |
| 050-1110 | Single Position |
| 050-1113 | Two-Position, Intertrip |

